

aiwa

COMPACT disc DIGITAL AUDIO

XP-V732 YUC

COMPACT DISC PLAYER

ENGLISH

OPERATING INSTRUCTIONS

AIWA CO.,LTD.

http://www.aiwa.co.jp

8C-HC7-701-01

011218BMK-U-A

Printed in China

OWNER'S RECORD

For your convenience, record the model number and the serial number (you will find it inside the battery compartment of your set) in the space provided below. Please refer to them when you contact your Aiwa dealer in case of difficulty.

Model No.	XP-V732
Serial No.	

NOTE

This equipment has been tested and found to comply with the limits for a Class B digital device, pursuant to Part 15 of the FCC Rules. These limits are designed to provide reasonable protection against harmful interference in a residential installation.

This equipment generates, uses, and can radiate radio frequency energy and, if not installed and used in accordance with the instructions, may cause harmful interference to radio communications. However, there is no guarantee that interference will not occur in a particular installation. If this equipment does cause harmful interference to radio or television reception, which can be determined by turning the equipment off and on, the user is encouraged to try to correct the interference by one or more of the following measures:

- Reorient or relocate the receiving antenna.
- Increase the separation between the equipment and receiver.
- Connect the equipment into an outlet on circuit different from that to which the receiver is connected.
- Consult the dealer or an experienced radio/TV technician for help.

CAUTION

Modifications or adjustments to this product, which are not expressly approved by the manufacturer, may void the user's right or authority to operate this product.

This Class B digital apparatus complies with Canadian ICES-003.

PRECAUTIONS

To maintain good performance

- Do not use the unit in places which are extremely hot, cold, dusty or humid. In particular, do not use or keep the unit in following places.
 - in a high humidity area such as a bathroom
 - near a heater
 - in an area exposed to direct sunlight (e.g., inside a parked car, where it can become extremely hot)
 - near sources of strong magnetism, such as televisions, speakers, or magnets
 - where there is a lot of movement or vibration, such as on a car dashboard or an unstable shelf
- Do not open the battery compartment with wet hands.
- Wipe the unit thoroughly before inserting batteries and after use.
- Do not soak the unit in water.
- Before connecting the AC adaptor or the headphones etc., be sure to confirm the power is off.

For safety

- Use only an AC adaptor whose rated output is DC 5-6 V, 250-300 mA.
- Do not attempt to disassemble the unit. Laser rays from the optical pickup are dangerous to the eyes.
- Make sure that pins or other foreign object do not get inside the player.
- Take care not to drop the unit or subject it to strong shocks.
- To keep dust from the pickup lens, keep the disc compartment lid closed after use. Never touch the lens.
- If you hear no sound when playing a disc, DO NOT turn the volume up high because music could suddenly start at high volume. Turn the volume control to the lowest level before starting playback and slowly turn it up to the desired level.

Notes on listening with the headphones

- Listen at moderate volumes to avoid hearing damage.
- Do not wear the headphones while driving or cycling. It may create a traffic hazard.
- You should use extreme caution or temporarily discontinue use in potentially hazardous situations, such as walking, jogging, etc.
- Wear them properly; L is left, R is right.

Note on condensation

If the unit is suddenly moved from a cold place to a warm place, it may result in condensation on the pickup lens and malfunction or playback difficulties. Should this occur, leave the unit for a few hours, then try playback again.

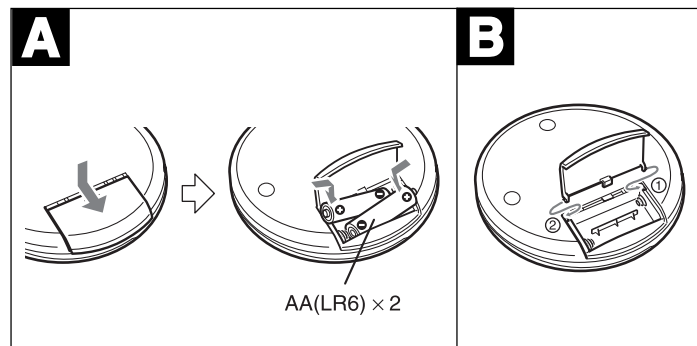

Highlighted letters in the text of this manual correspond to the illustrations.

USING ON DRY CELL BATTERIES → A

Open the battery compartment and insert two size AA (LR6) alkaline batteries with the + and - marks correctly aligned.

Battery replacement

The battery indicator in the display changes first from to , then to according to the remaining power of the batteries. Replace the batteries when lights. If the unit remains in use after lights, "Lo-bAtt" appears and operation stops.

Battery life (using alkaline batteries LR6)

The setting of the E•A•S•S switch	Battery life
48	Approx. 41 hours
12	Approx. 30 hours

Battery life may vary depending on conditions of use.

If the cover of the battery compartment comes off → E

Notes on dry cell batteries

- Make sure that the + and - marks are correctly aligned.
- Do not mix different types of batteries, or an old battery with a new one.
- To prevent the risk of electrolyte leakage or explosions, never recharge the batteries, apply heat to them, or take them apart.
- When not using the batteries, remove them to prevent needless battery wear.
- If liquid leaks from the batteries, wipe thoroughly to remove.

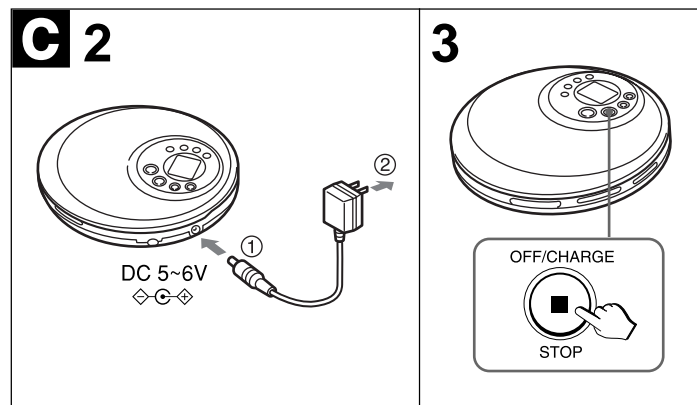

USING ON RECHARGEABLE BATTERIES → C

- Be sure to use size AA Ni-Cd 1.2 V 700 mAh rechargeable batteries, which are commercially available.
- Be sure to read the instructions of the purchased rechargeable batteries before use.
- When using on rechargeable batteries for the first time, charge them until the battery indicator goes out.
- Before charging the batteries, close the disc compartment. You cannot charge the batteries while it is open.

1 Insert the optional rechargeable batteries with the + and - marks correctly aligned.

2 Connect the optional AC adaptor.

- ① to DC 5-6 V jack
- ② to a wall outlet

3 Keep ■ STOP/OFF/CHARGE pressed for about 2 seconds to start charging.

"C-on" appears and the battery indicator blinks. When charging is completed, "OFF" flashes a few times, and the battery indicator goes out. Recharging exhausted batteries takes about 6 hours. After charging, disconnect the AC adaptor.

Time to recharge the batteries

Recharge the batteries when lights. If the unit remains in use after lights, "Lo-bAtt" appears and the current operation stops.

Force charging

When recharging stops after only few minutes or the batteries cannot be fully recharged, press ■ STOP/OFF/CHARGE while pressing PLAY MODE to force charging.

- Do not activate the force charging on the unit when there is no battery inserted or when dry cell batteries are inserted. Doing so may cause malfunction.

To stop charging

Press ■ STOP/OFF/CHARGE during charging.

Time to replace the batteries

Replace the batteries with new ones if they lost their capability to charge fully.

ATTENTION:

The product you have purchased can be powered by nickel cadmium batteries which are recyclable. At the end of their useful life, under various state and local laws, it is illegal to dispose of these batteries into your municipal waste stream. Please call 1-800-289-2492 for information on how to recycle these batteries.

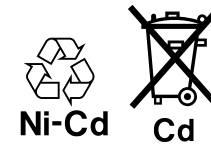

USING ON AC HOUSE CURRENT

Connect the optional AC adaptor in the same way as when recharging the batteries.

During operation on AC house current, all of the battery indicators turn off.

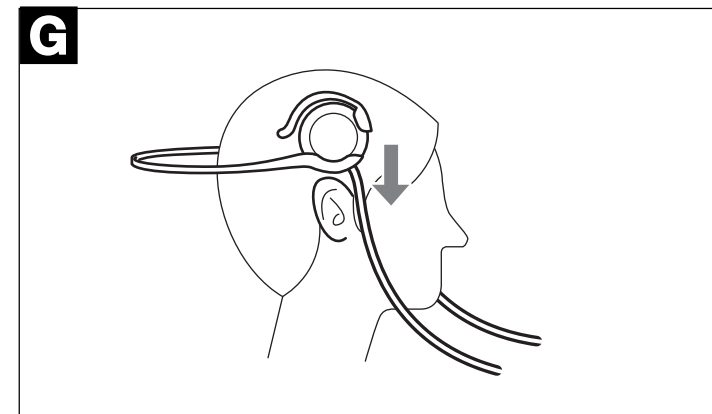
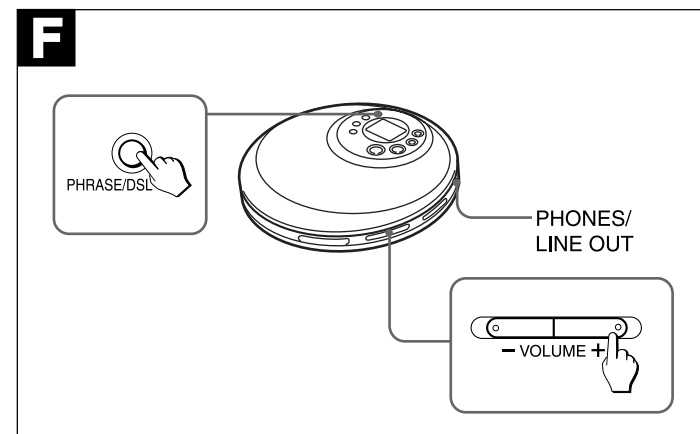
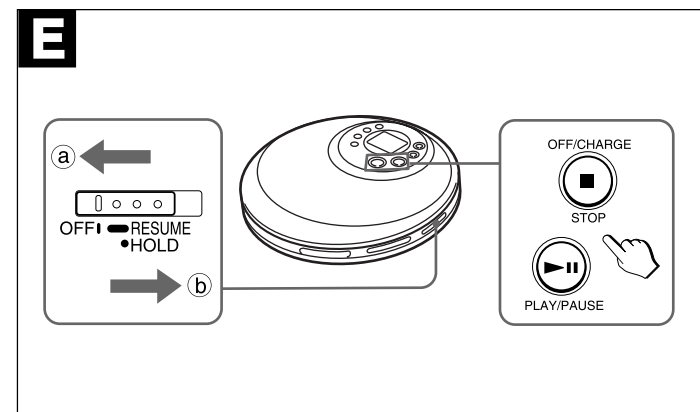
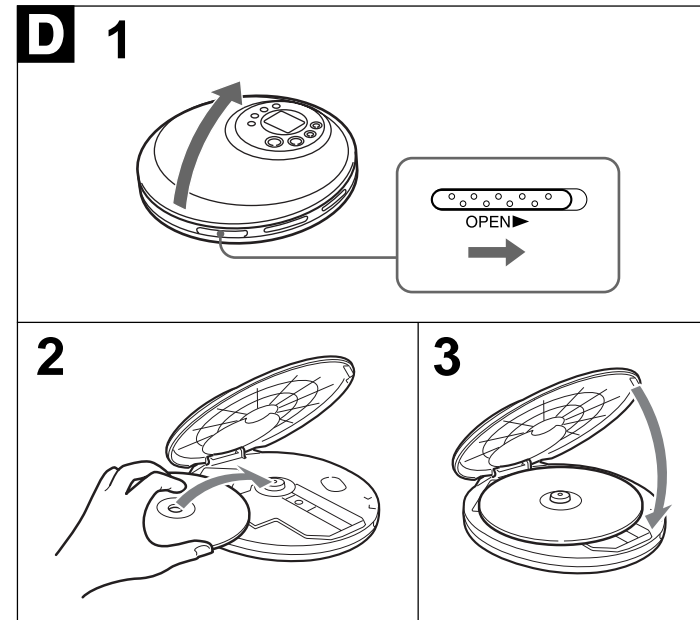

BEFORE PLAYBACK

Inserting a disc → D

- 1 Slide the OPEN switch to open the disc compartment.
- 2 Place a disc in the center with the label side facing up.
- 3 Close the disc compartment.

To remove the disc

Hold the disc at its edge and pick it up while pressing the pivot gently.

Note

- The unit may not play a CD-R/RW disc that is recorded on personal computers or some kinds of CD-R/RW recorders because of differences in recording platforms.
- Do not attach any adhesive label to either side (the recordable side or the labeled side) of a CD-R/RW disc. It may cause malfunction.

HOLD switch → E

Release HOLD. → a

When not using the unit, set HOLD to the hold position. → b

Accidentally pressed buttons will not function. If ► PLAY/PAUSE is pressed when HOLD is set to the HOLD position, "HOLD" flashes in the display.

Turning the power on → E

Press ► PLAY/PAUSE.

Power is turned on and playback starts.

Note

- "Err" appears on the display in the following cases:
 - When you try to play the unit without a disc in the disc compartment.
 - When you play a disc placed upside-down or a defective disc.

Standby mode → E

When an operation finishes, the unit goes into standby mode until the auto power off function automatically turns off the power.

To enter standby mode, press ► PLAY/PAUSE to start playback, then press ■ STOP/OFF/CHARGE.

Turning the power off → E

Press ■ STOP/OFF/CHARGE in standby mode.

- If no new operations are done within 30 seconds from the end of last operation, the power is turned off automatically. (Auto power off function)

Adjusting the sound → F

Connect the supplied headphones to the PHONES/LINE OUT jack. An amplified speaker system can be connected instead to enjoy the CD sound.

Volume

Press VOLUME+ or - to adjust the volume level.

DSL

Hold down PHRASE/DSL for more powerful sound and deeper bass.

DSL lights up.

Hold down PHRASE/DSL again to return to normal playback.

How to wear the headphones → G

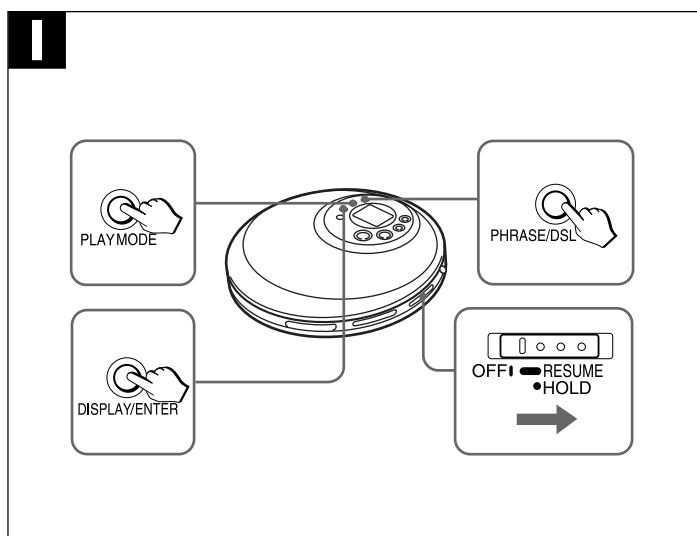
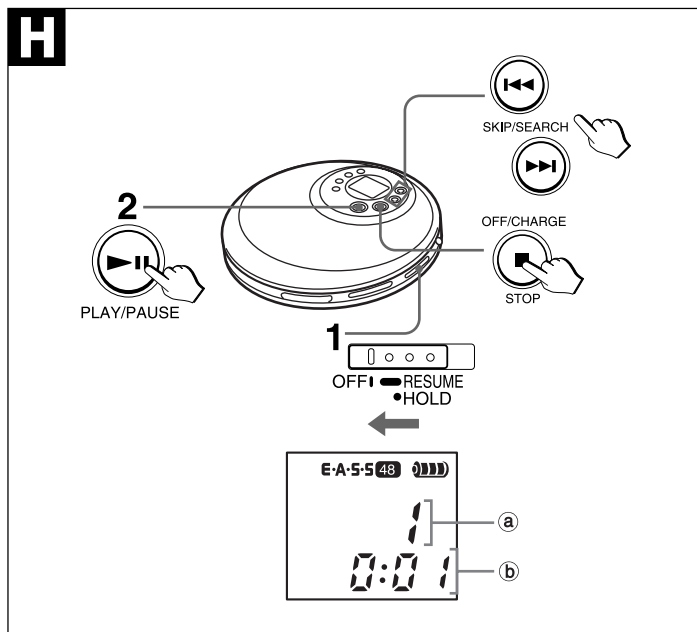

PLAYBACK → H

- 1 Release HOLD.
- 2 Press ►||PLAY/PAUSE.
Playback starts from the first track.
 - a track number
 - b elapsed playing time

Basic operation

To stop	Press ■STOP/OFF/CHARGE.
To pause	Press ► PLAY/PAUSE. To resume, press it again.
To search for the beginning of a track	Press ◀◀ or ▶▶.
To locate a desired passage	Keep ◀◀ or ▶▶ pressed. Release the button at the start of desired passage.

Display during playback → I

Press DISPLAY/ENTER repeatedly during playback.

With each press, the display changes as follows.

- ① Track display and elapsed playing time (normal display)
- ② Track display and remaining playing time of the track in play
- ③ Remaining number of tracks and remaining playing time

Note

- When the total remaining time of the programmed tracks is 100 minutes or over, the time is not displayed.
- When timer-off is set, the remaining time of timer-off is displayed between ① and ②.

Resume function → J

Set HOLD to RESUME.

"RESUME" appears, and you can start playback from the point where you stopped playback by pressing ■STOP/OFF/CHARGE.

When the resume function is on, all-track repeat is selected automatically.

To cancel resume play, set HOLD to OFF.

Note

- Resume play may start at a point up to about 30 seconds behind or ahead of the stopped point. Resume play may not operate if you stopped within the last 30 seconds of the final track.
- Resume play will be canceled if you open the disc compartment. If the unit is turned off, resume play will not be canceled. In this case, be sure to set HOLD to OFF before changing discs.

Random/Repeat play → K

Press PLAY MODE repeatedly to change the play mode as follows.

- ① 1: one-track repeat
- ② : all-track repeat
- ③ RNDM/: random repeat
- ④ RNDM: random
- ⑤ normal playback

Note

You cannot go back to the previous track by pressing ◀◀ during random play.

Phrase repeat play → L

Press PHRASE/DSL during playback.

With each press, playback returns to 5 seconds before.

Note

You cannot return to the previous track by pressing PHRASE/DSL.

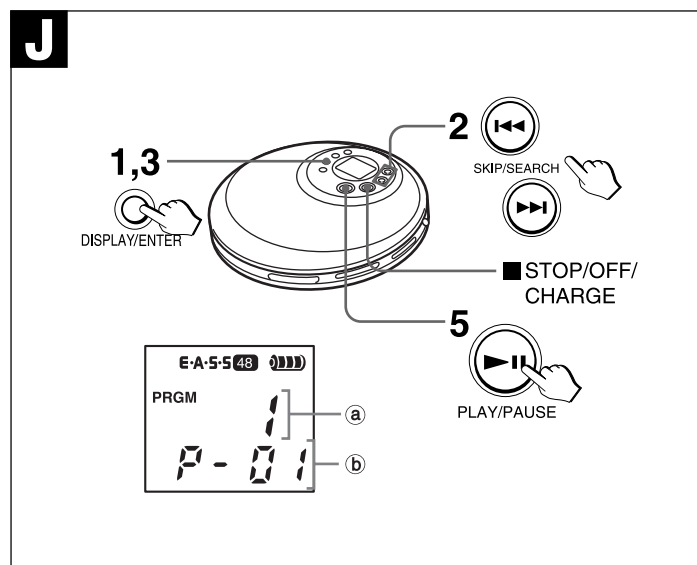

PROGRAM PLAY → J

Up to 24 tracks can be selected for program play.

- 1 Press DISPLAY/ENTER in standby mode to display "P-01".
- 2 Select the desired track by pressing ◀◀ and ▶▶.
 - a track number
 - b program number
- 3 Press DISPLAY/ENTER within 8 seconds.
If it is not pressed within 8 seconds, the track number changes to 00. Repeat from step 2 again.
- 4 Repeat steps 2 and 3 to program more tracks.
- 5 Press ►||PLAY/PAUSE to start program play.

To stop program play

Press ■STOP/OFF/CHARGE.

To add tracks to the program

Repeat steps 1 through 3 in standby mode. You can add tracks to the end of the program.

To erase the program

Press ■STOP/OFF/CHARGE in standby mode.

To check the programmed tracks

Press DISPLAY/ENTER repeatedly in standby mode.
The number of each programmed track will be displayed in the order of playback.

Note

- The program is also erased when the disc compartment is opened or the auto power off function turns the power off.
- When 24 tracks are programmed, "P-FULL" appears, and no more tracks may be added.
- You cannot go back to the previous track by holding ◀◀ pressed during program play.
- Repeat play and random play can be performed during program play.

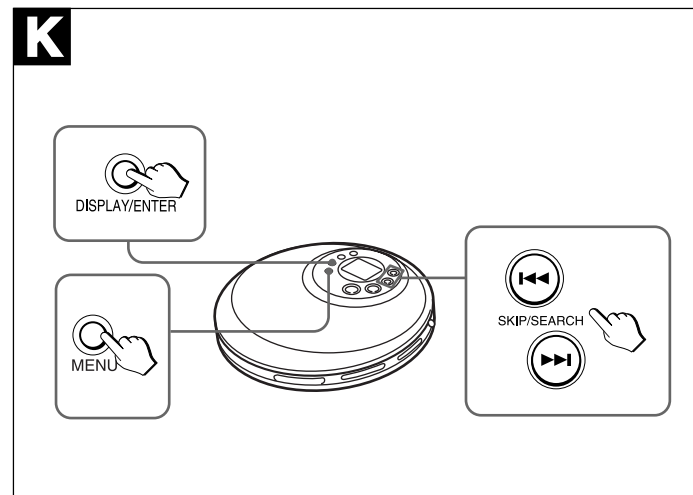

OTHER FUNCTIONS → K

You can set on or off timers, Jog beat, or E•A•S•S (Electronic Anti-Shock System.)

Press MENU repeatedly to select the desired mode.

With each press, the display changes as follows.

- ① OFF (Timer-off)
- ② ON (Timer-on)
- ③ bEAt (Jog beat)
- ④ E•A•S•S (Electronic Anti-Shock System)

For details of each operation, refer to the following.

Note

Timer-off and Timer-on settings are canceled, if the unit is turned off/on after setting is completed or when recharging the batteries.

OFF (Timer-off)

Timer-off function turns off the unit after a specified time.

- 1 Press ◀◀ or ▶▶ to set the hour and then press DISPLAY/ENTER.
- 2 Press ◀◀ or ▶▶ to set the minute and then press DISPLAY/ENTER.

The setting is completed.

When timer-off is set, all-track repeat is selected automatically and Auto power off function is disabled.

Adjustable range: up to 12 hours 59 minutes

To cancel the timer-off, press MENU to display "quit" and then press DISPLAY/ENTER.

ON (Timer-on)

Timer-on function turns on the unit after a specified time.

- 1 Press ◀◀ or ▶▶ to set the hour and then press DISPLAY/ENTER.
- 2 Press ◀◀ or ▶▶ to set the minute and then press DISPLAY/ENTER.

The setting is completed and the power is turned off automatically.

Adjustable range: up to 12 hours 59 minutes

bEAt (Jog beat)

Jog beat function beeps at a regular pace.

Press ◀◀ or ▶▶ to set the number of beeps in a minute and then press DISPLAY/ENTER.

To cancel Jog beat, press MENU to display "quit" and then press DISPLAY/ENTER.

Note

While Jog beat function is set, Auto power off function is disabled.

E•A•S•S (Electronic Anti-Shock System)

The E•A•S•S 3x function reduces skipping or muting of the sound when the unit is subjected to shock.

Press ◀◀ or ▶▶ to select "12" or "48" and then press DISPLAY/ENTER.

12 or 48 lights up and the player keeps about 48 seconds or 12 seconds of playback sound in its memory.

Note

- Before jogging with this unit, allow sufficient time for the memory buffer to fill up completely (ideally about 20 seconds).
Continuous shock or vibration may cause the sound to be interrupted even if the E•A•S•S 3x function is activated. This is normal and not a malfunction. Should you experience an interruption in sound, stabilize the unit for a few seconds, then resume your activity.
- When the E•A•S•S 3x function is activated, motor noise is heard as the motor periodically rotates at high speed during playback. This is not a malfunction.
- When you set the E•A•S•S to 12, quality of sound will be better than when you set it to 48.

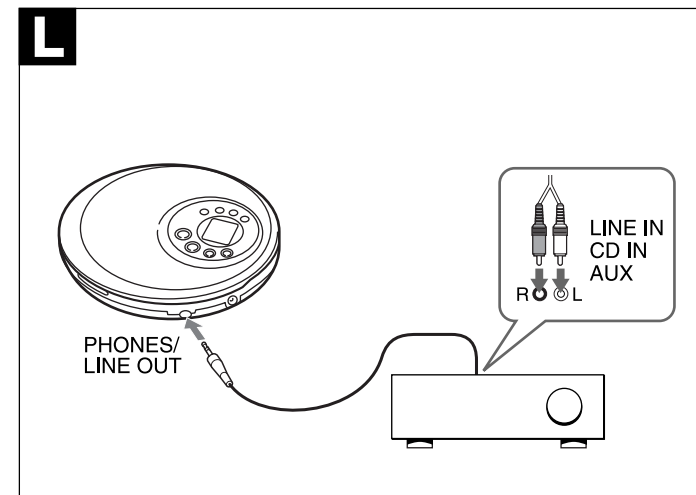

CONNECTING TO AN EXTERNAL UNIT

To PHONES/LINE OUT jack → M

Use a commercially available connection cord which has a ø3.5 mm stereo mini-plug at one end and two phono plugs at the other end.

Connect the stereo mini-plug to the PHONES/LINE OUT jack of the unit and connect the phono plugs to the analog input terminals of the external unit, such as the amplifier or the equipment with a built-in amplifier. The CD sound can be heard through the connected audio system.

Note

- Turn off the power of both units before connection.
- DO NOT connect to the PHONO inputs of an amplifier (with a built-in phonoequalizer-amplifier).
- Adjust the volume and DSL on this unit.

MAINTENANCE

To clean the pickup lens

If the lens becomes dirty, the player will skip or not play. If this occurs, clean the lens in the following manner.

- To remove dust or dry particles, first use a camera lens blower/brush to blow a few times to loosen particles, then gently brush the lens clean. Finish by blowing the lens again.
- To remove fingerprints, use a cotton swab dipped in lens cleaning solution. Wipe gently from the center to the edge. Lens cleaning solution is commercially available.

Note

Take care not to get too much solution on the swab, which could flow into the unit and cause damage.

Pressing too strongly with the swab could scratch or break the lens.

To clean the discs

Before playing, wipe the disc from the center out with a cleaning cloth. After playing, store the disc in its case.

SPECIFICATIONS

Tracking system	3-beam laser
Laser pickup	Semiconductor laser
D/A conversion	8-times oversampling digital filter + 1-bit DAC
Frequency response	20 – 20,000 Hz
Output	PHONES/LINE OUT jack (stereo mini-jack)
Maximum output	12 mW + 12 mW (16 ohms at 1 kHz) 500 mV (47 k ohms at 1 kHz)
Power supply	DC 3 V using two size AA (LR6) alkaline batteries DC 2.4 V using two optional rechargeable batteries (Ni-Cd 1.2 V 700 mAh) AC house current using the optional AC adaptor
Maximum outside dimensions	132 (W) × 22 (H) × 145.8 (D) mm (5 ¹ / ₄ × 7 ⁸ / ₈ × 5 ³ / ₄ in.) (excluding projecting parts and controls) Approx. 200 g (7.1 oz.) excluding batteries
Weight	
Accessories	Stereo headphones (1)

Specifications and external appearance of this unit are subject to change without notice.